

BEAM MOVE HEAD LIGHT

USER MANUAL

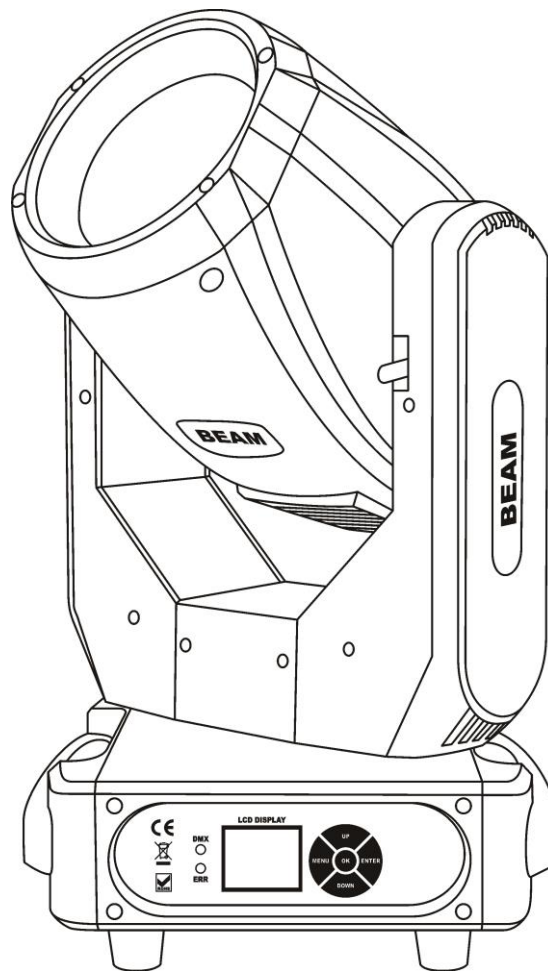

Please read over this manual before operation the light

CONTENTS

Chapter 1	Installation and attention	1
1.1	Maintenance	1
1.2	Statement.....	1
1.3	Safety Precaution	1
1.4	Product Instruction	1
1.5	Cable connection (DMX)	2
1.6	Rigging (Optional)	2
Chapter 2	Panel operation	4
2.1	Brief	4
2.2	Operation.....	4
2.2.1	Operate light with touch or KEY	4
2.2.2	Parameter value setting	4
2.2.3	Boolean parameter setting	5
2.2.4	Sub Menu (Parameter)	5
2.3	Operation and parameter instruction	5
2.3.1	ADDR--> Address: Set DMX Address.....	6
2.3.2	MODE--> WorkMode: Set Light work mode	6
2.3.3	DISP-->DISPLAY: Set display	7
2.3.4	TEST--> TestMode	7
2.3.5	ADVA-->Advanced: Set light run parameter	8
2.3.6	STAT-->Status: View status	9
Chapter 3	Channel description	10
3.1	Channel table.....	10
3.2	Channel Detail.....	错误!未定义书签。
3.2.1	COLOR Detail.....	错误!未定义书签。
3.2.2	GOBO Detail.....	错误!未定义书签。

Chapter 1 Installation and attention

1.1 Maintenance

- To reduce the risk of electrical shock or fire, do not expose this unit to rain or moisture.
- Intermittently using will extend this item's service life.
- Please clear the fan ,fan net , and optical lens in order to keep good work state.
- Do not use the alcohol or any other organic solvent to wipe the shell.

1.2 Statement

The product has perfect performance and integrity packing. All users should be strictly complying with the warning and operating instructions as stated. Or we aren't in charge of any result by misusing. Any damage resulting by misuse is not within the Company's warranty. Any fault or problem caused by neglecting the manual is also not in the charge of dealers.

Note: All information is subject to change without prior notice.

1.3 Safety Precaution

- In order to guarantee the product's life, please don't put it in the damp places or even the environment over 60degrees.
- Always mount this unit in safe and stable matter.
- Install or dismantle should operate by professional engineer.
- Using lamp, the change rate of power voltage should be within $\pm 10\%$, If the voltage is too high, it will shorten the light's life; If it's not enough, will influence the effect.
- Please restart it 20 minutes later after turning off light , until full-cooling. Frequent switching will reduce the life span of lamps and bulbs; intermittent using will improve the life of bulbs and lamps.
- In order to make sure the product is used well, please read the Manual carefully.

1.4 Product Instruction

- lamp: MSD 295w (life:2200 hours Color temperature: 8000K)
- Channel mode:16 DMX512 Channel
- Pan scan: 540 (16bit) Electric correction
- Tilt scan: 270 (16bit) Electric correction
- Amazing dot matix, four tact switch, 180 turning show
- Color wheel: one color wheel, 14 kinds of color chips in one color wheel
- Gobo: 14 gobos
- Effect Wheel: Rotation eight prism, effect move , frost
- 0-100% mechanical dimming, mechanical dimming and free dimming available.
- strobe macro control available.
- Lens optical system achanical fouce .beam angle 0~4 °

- Over heat protection
- Power Input: 100-240V, 50/60Hz
- Power Dissipation: 350W
- IP level :IP20
- Magnetic ballast and AC/Dc power supply
- Product Size: 523×337×511mm
- Packing Size: 635X440X725
- Net weight: 19.5KG

1.5 Cable connection (DMX)

Use a cable conforming to specifications EIA RS-485: 2-pole twisted, shielded, 120Ohm characteristic impedance, 22-24 AWG, low capacity. Do not use microphone cable or other cable with characteristics differing from those specified. The end connections must be made using XLR type 3 or 5-pin male/female connectors. A terminating plug must be inserted into the last projector with a resistance of 120Ohm (minimum 1/4 W) between terminals 2 and 3.

IMPORTANT: The wires must not make contact with each other or with the metal casing of the connectors. The casing itself must be connected to the shield braid and to pin 1 of the connectors.

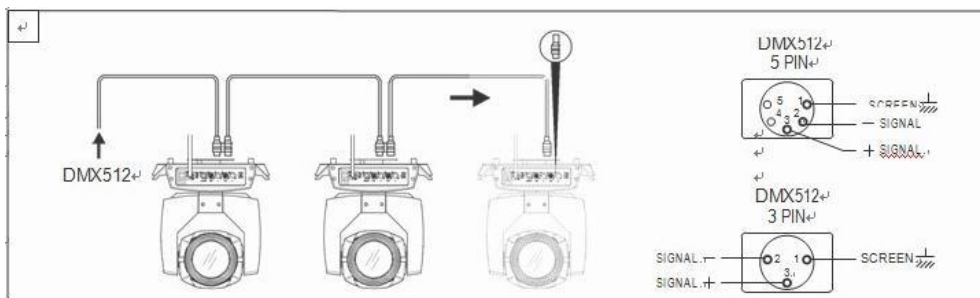

Figure 1 DMX Cable connection

1.6 Rigging (Optional)

This equipment can be positioned and fixed by clamp in every direction of the stage. Locking system makes it easy to fasten to the bracket.

Attention! Two clamps is needed to fix the equipment. Every clamp is locked by fastener of 1/4 kind. Fastener can only be locked clockwise.

Attention! Fasten a safety string to the additional hole of side aluminum piece. The secondary accessory can not hang on the delivery handle. Nip the equipment on bracket.

- Check if rigging clamp (not including the one inside) damaged or not? If stand ten times weight as the equipment. Make sure the architecture can stand ten times weight as all the equipments, clamps, wirings and other additional fixtures.
- Screws for clamping must be fixed firmly. Take one M12 screw (Grade 8.8 or higher) to clamp bracket, and then screw the nuts.
- Level the two hanging points at the bottom of clamp. Insert fastener to the bottom, lock the

two levers by 1/4 rotating clockwise; then install another clamp.

- Install on safety string which stands at least ten times weight as equipment. Terminal of the accessory is designed for clamps.
- Make sure pan/tilt lock unlocked or not. Keep the distance more than 1M from equipment to flammable material or lighting source.

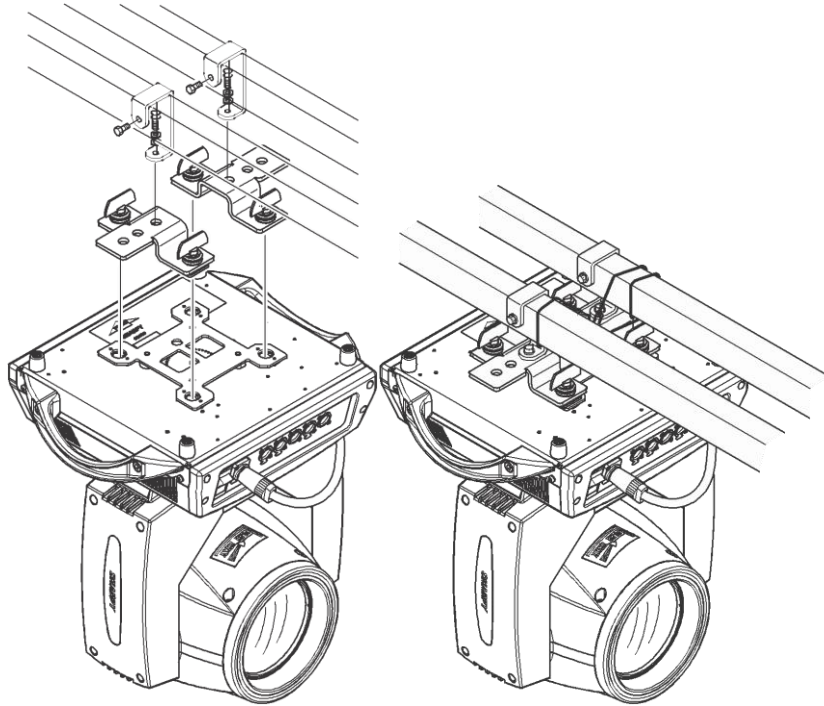

Figure 2 Installation

Chapter 2 Panel operation

2.1 Brief

The light panel diagram show as Figure 3, Left area is TFT Displayer, support touch, and right area is KEY, both of touch and KEY can operate light and setting.

Display & operation just like 'Android operation system', touch the item will set or modify setting.

Note: Prevent damage the touch or TFT displayer, Can not use sharp objects chick displayer.

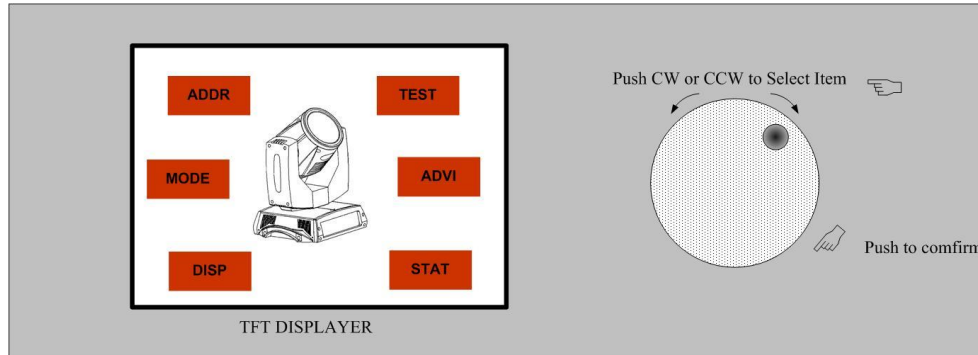

Figure 3 Panel diagram

2.2 Operation

2.2.1 Operate light with touch or KEY

- The left area is TFT Displayer and touch, chick item or value with finger will to complete operation of set light setting(parameters) or view light state.
- The area on the right hand side is 4 KEY, As auxiliary input interface, if disable touch function,, the KEYr can been choose to set the parameter.

2.2.2 Parameter value setting

When the selected item is value need to be modified, the dialog shown in Figure 4 will popup.

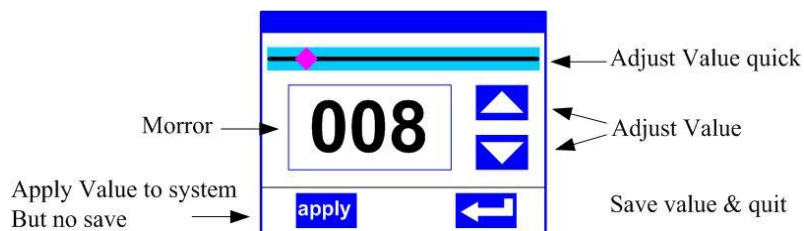

Figure 4 Dialog of value setting

- **Modify value:** Can quickly modify value via pull the slider to the desired position, or click the button of 'up' or 'down' whit finger on the right side to set the exact desired value, another way is roll encoder on the right hand side of panel.
- **Apply value:** When Value had been modified, Then press the bottom of 'apply' in the left corner to apply to the light, but hav't saved;
- **Save Value:** Any time, click on the lower right corner of the "OK" button, the setting will been saved into internal memory.

2.2.3 Boolean parameter setting

- when the selected parameters is a Boolean value (such as ON or OFF), can directly modify setting by chick corresponding item, the setting will been saved right now.
- When the parameter is a key item, chick corresponding item, a dialog shown in Figure 5 will been pop up ask for the confirm. Chick ‘sure’ to confirm.

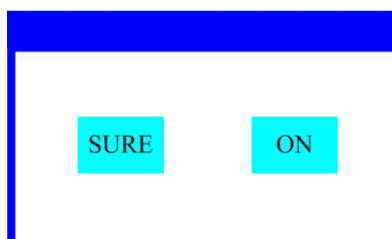

Figure 5 Dialog of confirm

2.2.4 Sub Menu (Parameter)

Chick item of main menu, enter corresponding sub menu, shown in Figure 6, total 6 sub menu, includes class of parameter and status:

- ADDRESS: Set light DMX address.
- WORKMOD: Set light work mode, master or slave mode when in auto run mode.
- DISPLAY: Set display parameter, eg. select language.
- TEST: Used for test light, modify DMX channel data to test function, the corresponding function of reference channel function table.
- ADVANCE: Set light running parameter.
- STATUS: view light current status.

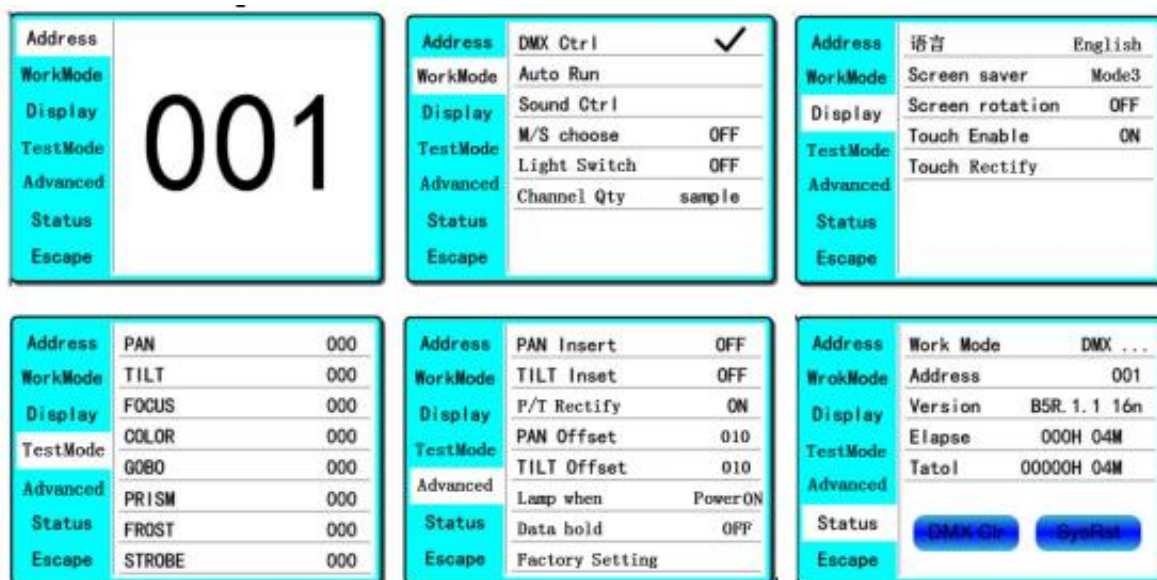

Figure 6 Parameter menu

2.3 Operation and parameter instruction

Via following operation, enter sub menu(parameter menu) shown in Figure 6

- In main menu, click 1/6 function button into corresponding parameter menu.
- In sub menu(page), click main item on the left side of display, can shift to corresponding sub menu(page) quickly.

2.3.1 ADDR--> Address: Set DMX Address

Click and select the "ADDR", can enter the page of DMX address setting, range from 1 to 512, the address code shouldn't is not greater than (512- channels quantity), otherwise the light will not be controlled. Following is the operation:

Enter the page of DMX address, as shown in Figure 7, click the blank area in right side of display will pop-up diglog as in Fig. 4, modify value, then click 'ENTER' to confirm and save DMX address code.



Figure 7 page of DMX Address

2.3.2 MODE--> WorkMode: Set Light work mode

Enter the page of 'WorkMode' as shown in Figure 8 and modify setting. Can set light work mode, control lamp and DMX channel mode.

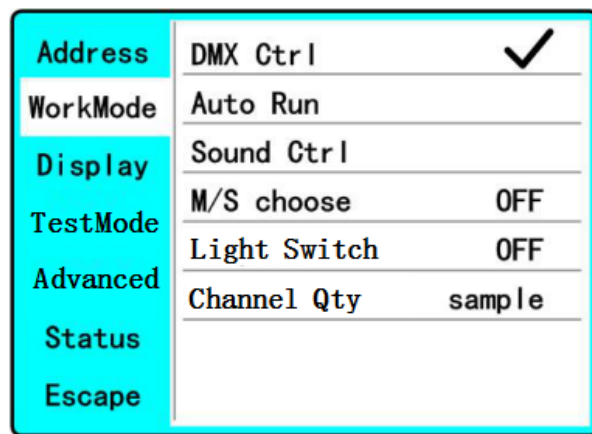

Figure 8 page of work mode

- ◆ **DMX Ctrl:** Choose to set DMX Mode,
- ◆ **Auto Run:** Choose to set Auto Mode,
- ◆ **Sound Ctrl:** Choose to set Sound Mode,
- ◆ **M/S Choose:** Available just in 'AUTO RUN' or 'SOUND Ctrl' mode.
ON--> Master. (Data will be send to other slave lamp immediately.)
OFF--> Slaver.(NOT send data to other lamp via DMX Cable).(Default)
- ◆ **Light Switch:**
ON--> Turn on the light,

OFF--> Turn off the light.

◆ **Channel Qty:** Light support 2 DMX Channel mode: sample or extend.

Simple --> 16CH.(Default)

Expand--> 20CH(or null).

2.3.3 DISP-->DISPLAY: Set display

Light support 2 language, rotation display, Enter page as shown in Figure9 to set parameter following:

Address	语言	English
WorkMode	Screen saver	Mode3
Display	Screen rotation	OFF
TestMode	Touch Enable	ON
Advanced	Touch Rectify	
Status		
Escape		

Figure9 page of display

◆ **Language:** English / 中文.

◆ **Screen Saver:** when panel is idle(these is no operation in 10 second), displayer will enter saver status.

OFF--> No screen saver.

Mode1--> Power-saving mode, turn off the display.

Mode2--> Displays the current address.

Mode3--> Displays the icon and the current working mode.(Default)

◆ **Screen Rotion: To turning display.**

ON--> Normal display.(Default)

OFF--> 180 °turning display.

◆ **Touch enable:** Disable or enable touch function,.

ON--> Enable touch function.(Default)

OFF--> Dosable touch function.

◆ **Touch adjust:** Adjust touch function. Normally, not enter this item.

2.3.4 TEST--> TestMode

Enter the page as shown in Figure 10, Light will into test mode, in this mode, the light does not receive the data for DMX controller.:

Address	PAN	000
WorkMode	TILT	000
Display	FOCUS	000
TestMode	COLOR	000
	GOBO	000
Advanced	PRISM	000
Status	FROST	000
Escape	STROBE	000

Figure 10 page of Test

- ◆ **PAN:** range for 0 to 255;
- ◆ **TILT:** range for 0 to 255;
- ◆ **FOCUS:** range for 0 to 255;
- ◆ **COLOR:** range for 0 to 255;
- ◆ **GOBO:** range for 0 to 255;
- ◆ **PRISM:** range for 0 to 255;
- ◆ **FROST:** range for 0 to 255;;
- ◆ **STROBE:** range for 0 to 255;

2.3.5 ADVA-->Advanced: Set light run parameter

Enter the page as shown in Figure 10, set the parameter of light:

Address	PAN Inset	OFF
WorkMode	TILT Inset	OFF
Display	P/T Rectify	ON
TestMode	PAN Offset	010
	TILT Offset	010
Advanced	Lamp when	Power ON
Status	Data hold	OFF
Escape	Factory Setting	

Figure 11 page of run parameter

- ◆ **Pan Invert: Reverse PAN move**
OFF--> Pan Normal move.(Default)
ON--> Reverse PAN move.
- ◆ **Tilt Invert: Reverse TILT move**
OFF--> Tilt Normal move.(Default)
ON--> Reverse Tilt move.
- ◆ **P/T Rectify: Disable or enable position rectify function.**
OFF--> Disable P/T rectify
ON--> Enable P/T rectify-(Default)
- ◆ **Pan Offset:** Set PAN original position. **Default: 10**
- ◆ **Tilt Offset:** Set TILT original position. **Default: 10**
- ◆ **Lamp when:**

- PowerON--> Turn on the lamp when power on.(Default)
- RstDone--> Turn on the lamp after reset.
- Manual--> Manually turn on the lamp.
- ◆ **Data hold:**
 - OFF--> When no DMX signal,return to middle position.(Default)
 - ON--> When no DMX signal,stop in the final position.
- ◆ **Factory Setting:** Restore all parameter to factory setting.

2.3.6 STAT-->Status: View status

Enter the page as shown in Figure 12:

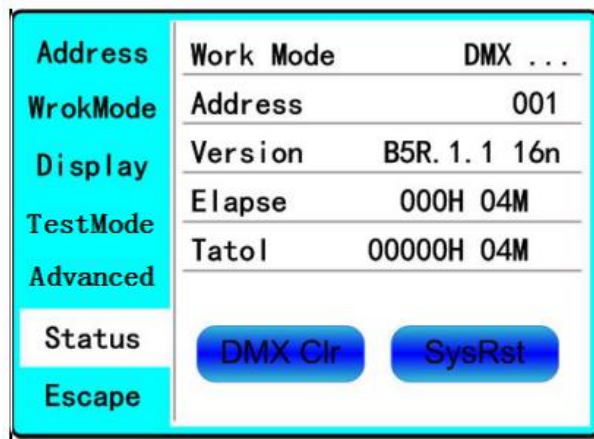

Figure 12 page of status

- ◆ **Work Mode:** Show the current working mode.
- ◆ **Address:** Show the current address.
- ◆ **Version:** Show the version of the lamp.
- ◆ **Elapse:** Working hours after turn on.
- ◆ **Tatol:** Cumulative hours of operation

DMX Clr

When <Data hold> set <ON>,click to clear DMX data, and make the lamp return to themiddle position.

SysRst

Click to reset.

Chapter 3 Channel description

3.1 Channel table

Table 1 Channel brief

通道 1	通道名	数值	描述
1	PAN	0~255	Pan movement by 540
2	TILT	0~255	Tilt movement by 270
3	PAN fine	0~255	Fine control of pan movement
4	TILT fine	0~255	Fine control of tilt movement
5	XY Speed	0~255	Fast to slow
6	Frost	0~127	Close frost
		128~255	Insert frost
7	Strobe	0-3	Close
		4-103	Fadeout slow to fast
		104-107	Open
		108-207	Free Strobe slow to fast
		208-212	Open
		213-251	Pulse Strobe slow to fast
8	Dimmer	252-255	Open
		0~255	Dimmer intensity from 0% to 100%
9	Color	0-4	White
		5-9	White+Color1
		10-14	Color1
		15-19	Color1+Color2
		20-24	Color2
		25-29	Color2+Color3
		30-34	Color3
		35-39	Color3+Color4
		40-44	Color4
		45-49	Color4+Color5
		50-54	Color5
		55-59	Color5+Color6
		60-64	Color6
		65-69	Color6+Color7
		70-74	Color7
		75-79	Color7+Color8
80-84	Color8		
85-89	Color8+Color9		

		90-94	Color9
		95-99	Color9+Color10
		100-104	Color10
		105-109	Color10~Color11
		110-114	Color11
		115-119	Color11+Color12
		120-124	Color12
		125-129	Color12+Color13
		130-134	Color13
		135-139	Color13+Color14
		140-144	Color14
		145-149	Color14+White
		150-200	Forwards rainbow from fast to slow
		201-255	Backwards rainbow from slow to fast
10	Gobo	0-4	White
		5-9	Gobo1
		10-14	Gobo2
		15-19	Gobo3
		20-24	Gobo4
		25-29	Gobo5
		30-34	Gobo6
		35-39	Gobo7
		40-44	Gobo8
		45-49	Gobo9
		50-54	Gobo10
		55-59	Gobo11
		60-64	Gobo12
		65-69	Gobo13
		70-125	Forwards rainbow from fast to slow
		126-130	Stop
		131-190	Backwards rainbow from slow to fast
		191-195	Gobo1 Shake, Slow to fast
		196-200	Gobo2 Shake, Slow to fast
		201-205	Gobo3 Shake, Slow to fast
206-210	Gobo4 Shake, Slow to fast		
		216-220	Gobo6 Shake, Slow to fast
		221-225	Gobo7 Shake, Slow to fast
		226-230	Gobo8 Shake, Slow to fast
		231-235	Gobo9 Shake, Slow to fast

		236-240	Gobo10 Shake, Slow to fast
		241-245	Gobo11 Shake, Slow to fast
		246-250	Gobo12 Shake, Slow to fast
		251-255	Gobo13 Shake, Slow to fast
11	Prism1	0-127	Close Prism
		128-255	Insert Prism1
12	Prism2	0-127	Close Prism
		128-255	Insert Prism2
13	Prism.Rot	0-127	0~400 degree
		128-187	Forwards rainbow from fast to slow
		188-195	Stop
		196-255	Backwards rainbow from slow to fast
14	Colorful	0-127	
		128-255	Insert colorful
15	Zoom	0~255	Zoom Large to small
16	Reset	100-105	Lamp Off (Over 3 seconds)
		200-205	Lamp on (Over 3 seconds)
		210-215	Reset XY(over 3 seconds)
		220-235	Reset effect moto(over 3 seconds)
		240-255	Reset all(over 3 seconds)
17	Led Strip	0-255	Effect Show
18	Led Strip Speed	0-255	Effect Show Speed